



## 703 Phantom Series

The Phantom range of TV lifts offers a huge selection of standard sizes to cater for most TV displays up to around 55". It is important to carefully check the physical TV dimensions before ordering as different display manufacturers have different housing sizes. The product is a step up from the Yo-Yo in that it is constructed entirely from anodised aluminium and can lift TV displays up to 100Kg.

The Phantom TV lift is also available with an automatic lid option. With an automatic lid, the system elegantly lowers the top panel out of the way before the TV rises in the chassis. This means that the system is not relying on the top of the TV display to push the panel open thus avoiding both damage or marking to lid or TV housing. The automatic lid device has its own motor and control box.



- Weight (kg) 10.00
- Colour Black
- Max. Lifting Capacity (kg) 100.00
- Maximum TV Size 55"
- Finish Black Anodised Aluminium
- Manufactured and assembled according to ISO :9001 standards.
- PATENT nr. 0001330426
- Using high quality materials such as: Anodised aluminium 110 EN AW – 6082/AlMg4Si 1
- Stainless steel grade 316.
- All items CE marked No: 2006/42/CE – 93/68 CEE.
- Lateral sliders are maintenance free and have a double prism for greater strength and durability.
- Transmission via reversible continuously rated electric motors for 12V & 24Vdc and 115V & 230V ac.
- Drive connection to stainless steel calibrated shaft via conical epicycloidal gearing, which reduces vibration and noise.
- Travel of mechanism limited by adjustable micro switches, with mechanical stops fitted in the unlikely event of a failure.
- Support brackets for TV screens are made from stainless steel with pre-drilled holes that align with the specific make and model of TV.
- Wiring is housed within a flameproof flexible covering that prevents the wiring from being crushed or cut.
- Devices with manual or electrical rotation have a safety device that ensures the TV cannot be lowered unless it is perfectly aligned.

### **Other important features include:**

- Gears and all moving parts are covered to prevent damage.
- Electrical components are housed in an ABS waterproof container IP 66.
- All components protected by circuit breaker.
- Safety device incorporated to prevent overloading or inverting the polarity.
- Pre-wired system with operation via two way switch (not supplied) or optional remote control with 2 or 4 channels depending on the number of functions.
- Optional FREE SHOCK SYSTEM which stops the unit operating immediately if it is subjected to excessive force.

### **Sizes**

Custom solutions are available on request. Please note, systems specified with an automatic lid are slightly larger than the standard TV lift.

All sizes can lift up to 100Kg.



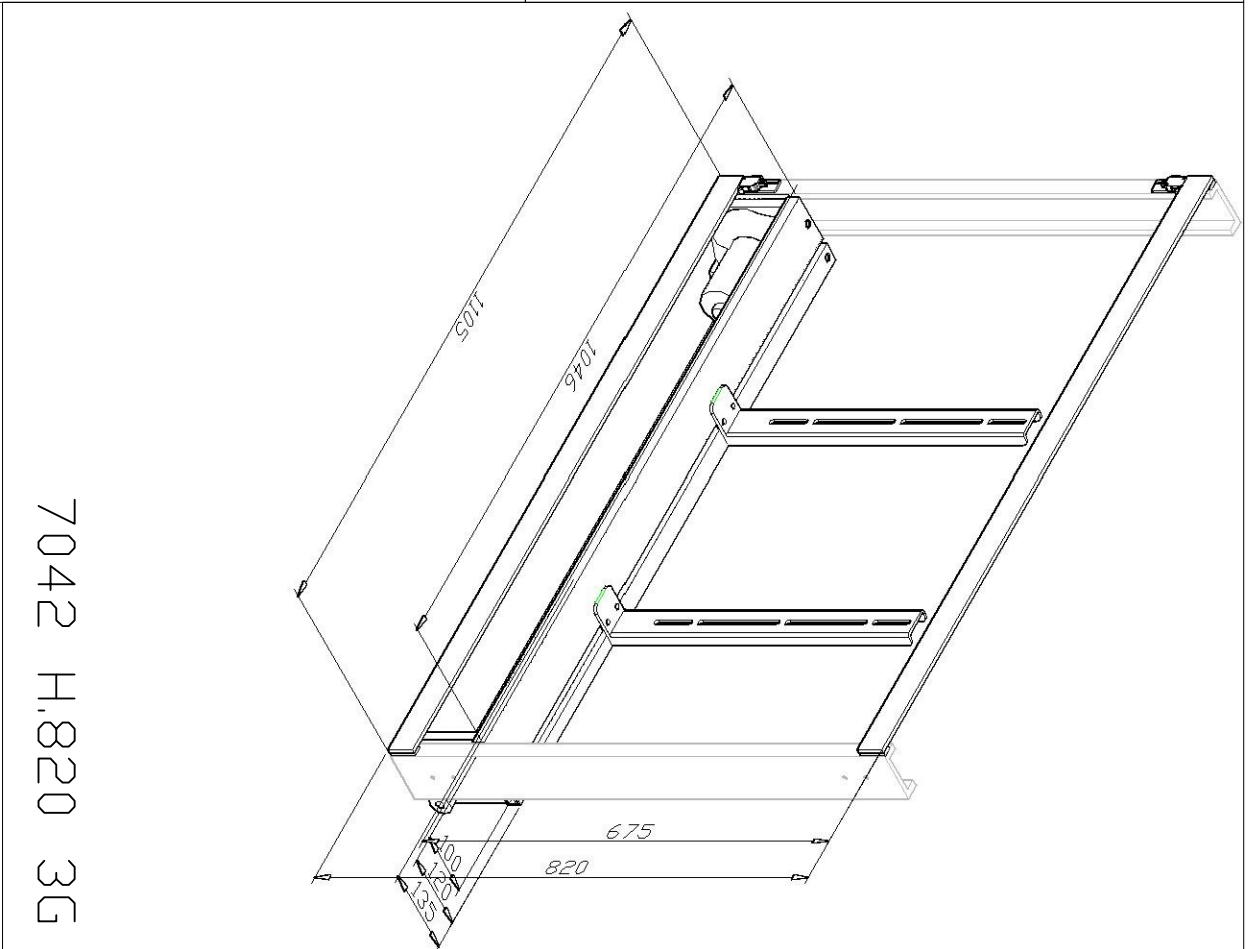
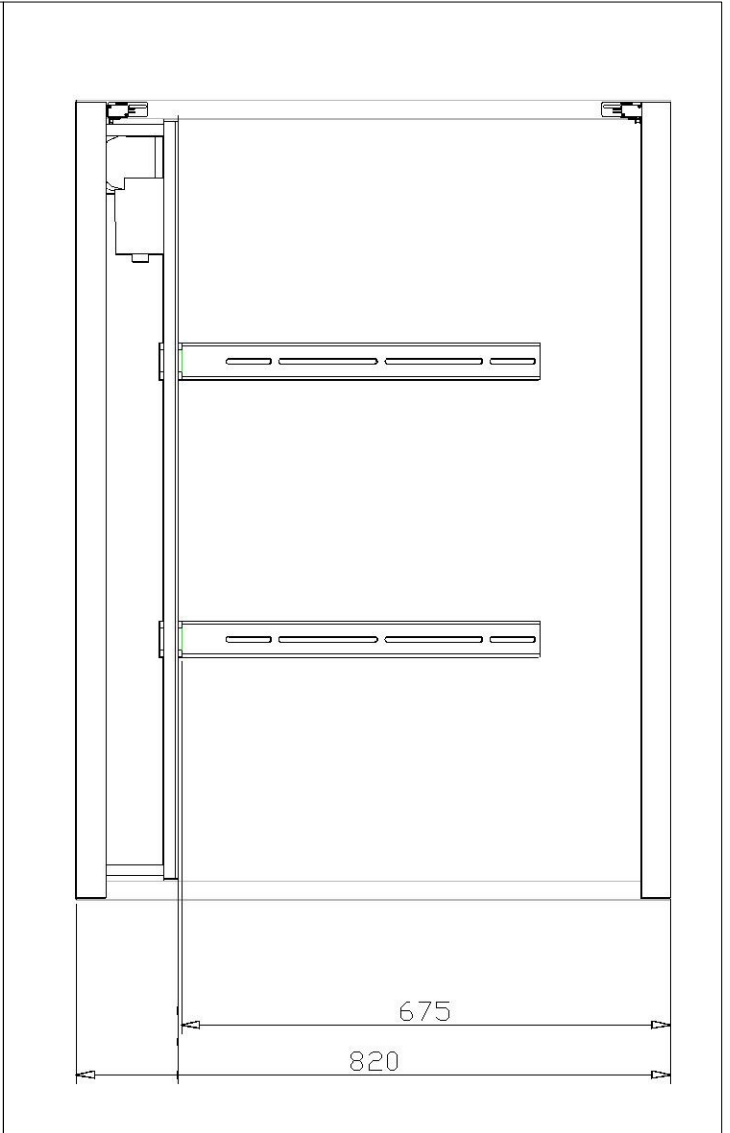
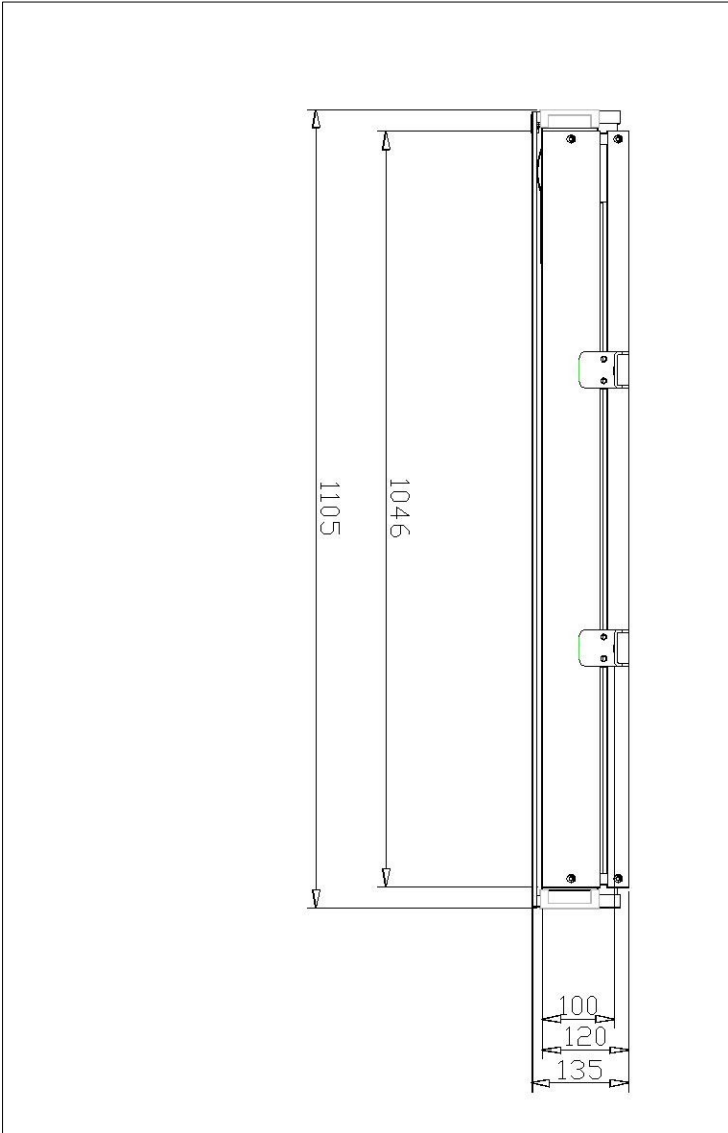

**GINEICO**

7042 H.820 3G

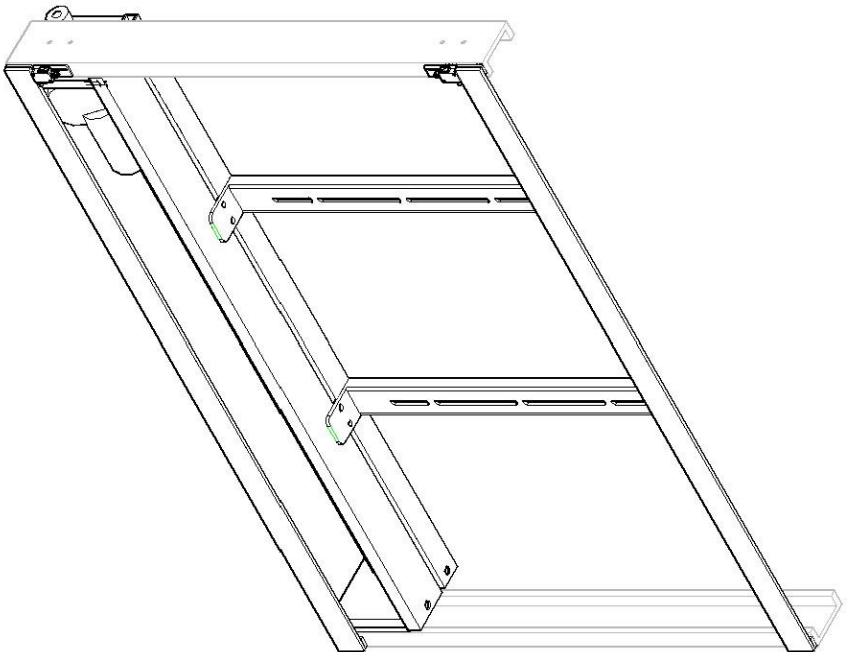
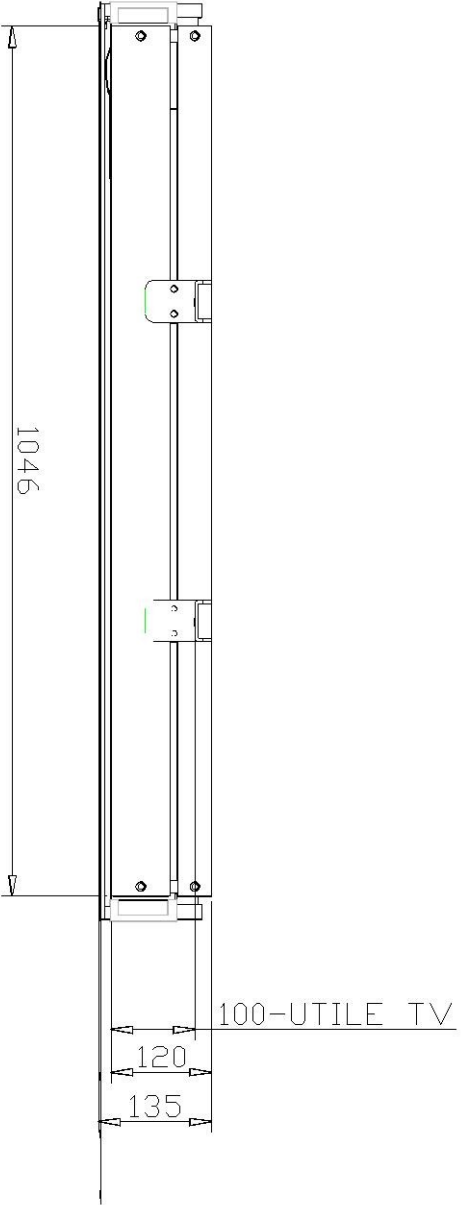
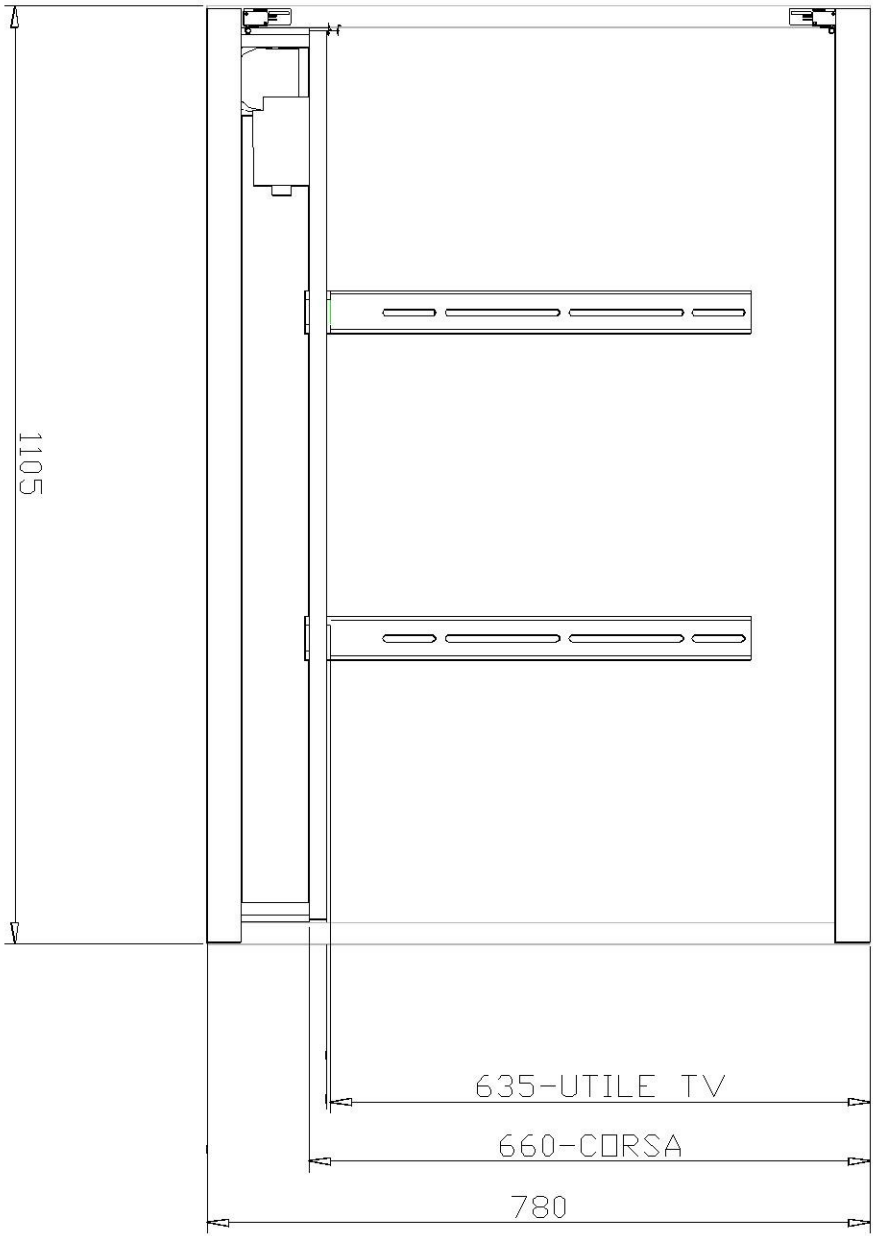

7042 H.780 3G

 GINEICO

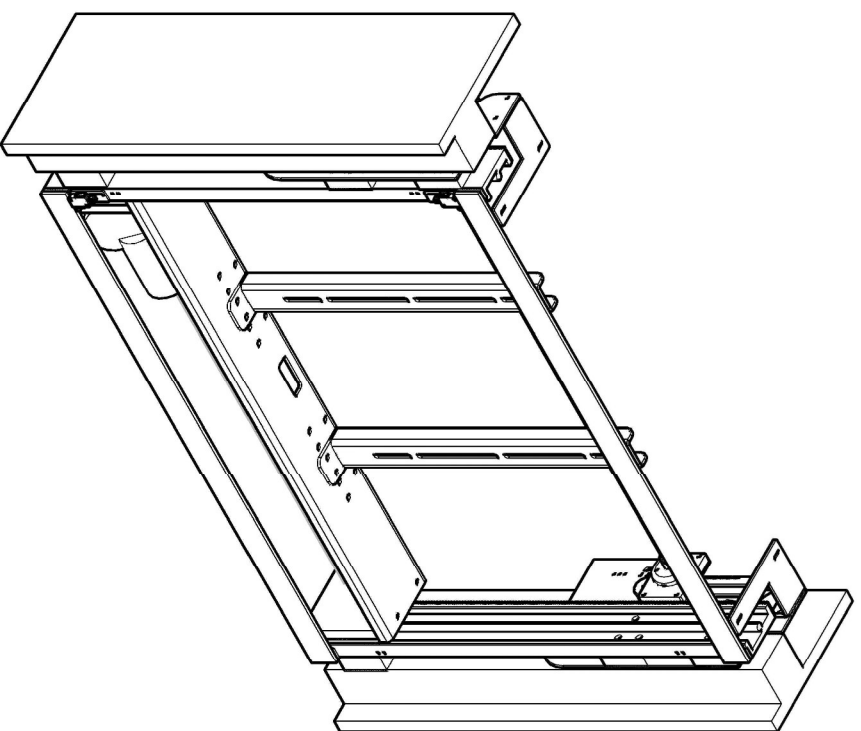
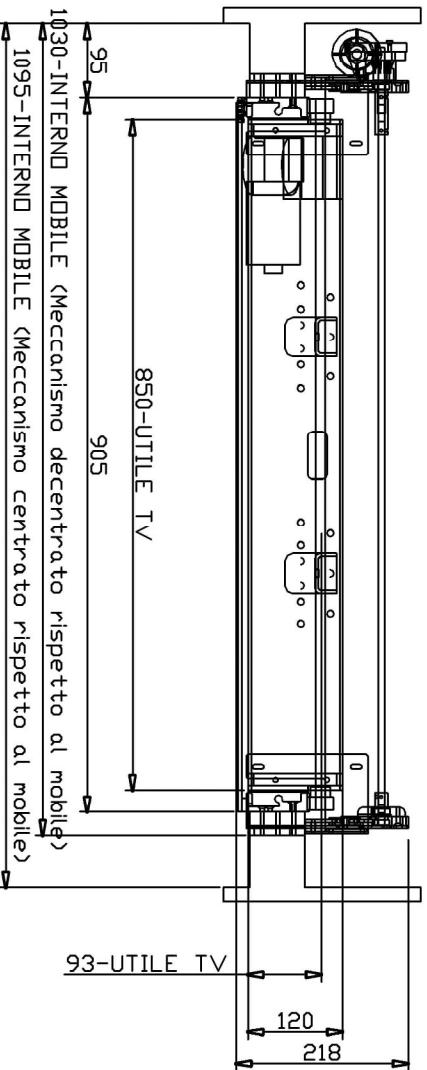
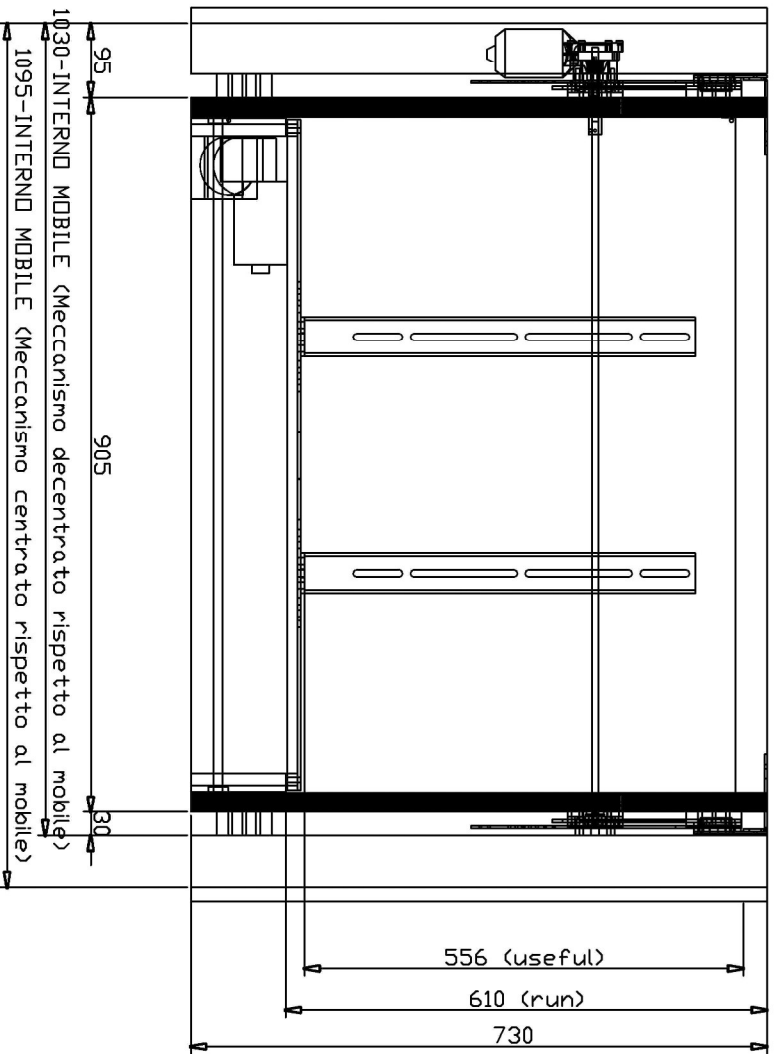

NOTO

Rimaniamo a disposizione per ulteriori chiarimenti

Codice articolato	Descrizione	Materiale
7031AL4G H730	Meccanismo 7031 con sportello 4G H730	Vari
N° disegno	Disegnato	Data
/	D. Bertin	04/10/2016
		Varie



GINEICO

Disegno eseguito a CAD, non sono ammesse modifiche.  
Questo disegno è di proprietà della SEA & SYMPHONY. La suddetta, ditta aderente al consorzio GINEICO, si riserva tutti i diritti sanciti dalla legge.