



Technical data

MODEL	MC²X16	MC²X16 LV
Rated speed (1)	5000 RPM	5000 RPM
Angular momentum (2)	5325 N·m·s	5325 N·m·s
Output torque (3)	16350 N·m	16350 N·m
Spool-up time to rated RPM	35 min	35 min
Spool-up time to stabilization	32 min	32 min
Power absorbed	3200 W max	3200 W max
AC Input voltage	200-240 Vac	90-120 Vac
Frequency	50-60 Hz	50-60 Hz
Noise output	< 70 dB	< 70 dB
Ambient air temperature	-10°C / +55°C	-10°C / +55°C
Weight (4)	480 kg (1058,2 lb)	480 kg (1058,2 lb)

- (1) Rated speed: flywheel speed (RPM: Revolutions per minute).
- (2) Angular momentum: it quantifies the torque that is necessary to balance the system in the time unit (Newtons meter second).
- (3) Output torque: torque generated by the rotor at rated speed (Newtons per meter).
- (4) Weight with control unit, excluding optional base plate accessory, standard or custom.

Dimensions

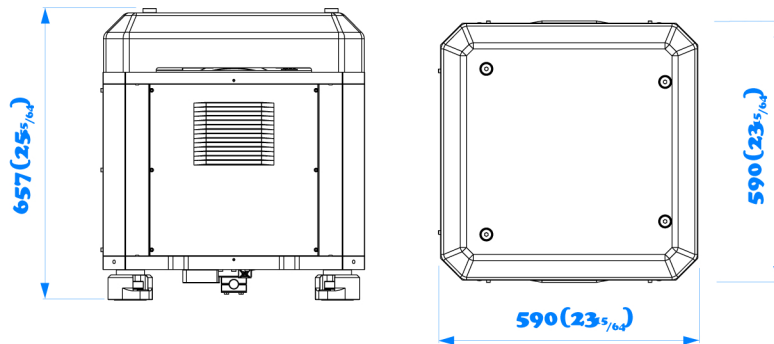

1.4 Dimensions with base plate (optional)

